

F. D. BLISS.

Die-Plates.

No. 135,314. Patented Jan. 28, 1873.

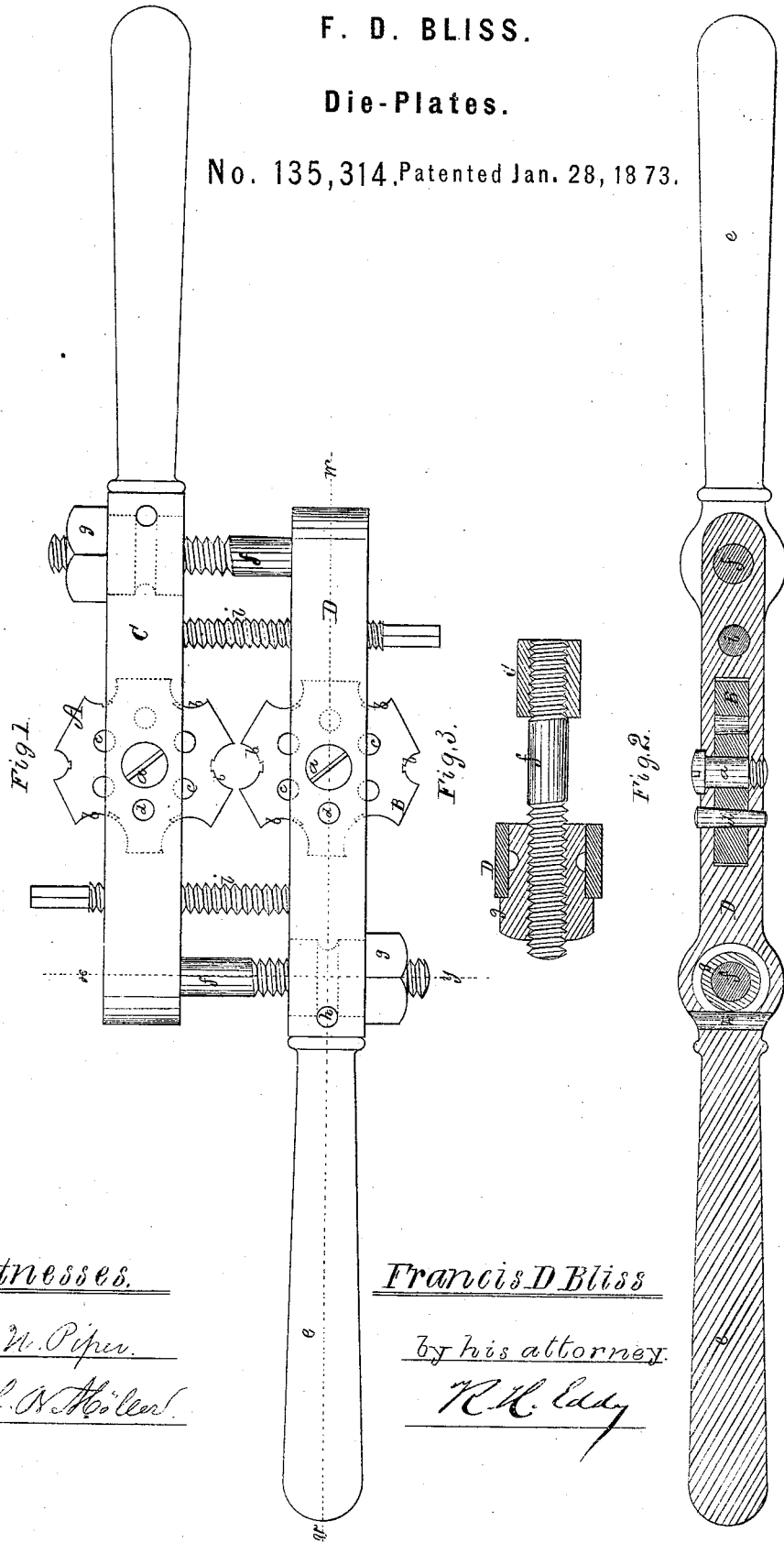

Witnesses.

S. M. Piper.

L. A. Höller.

Francis D. Bliss

by his attorney.

R. H. Eddy

UNITED STATES PATENT OFFICE.

FRANCIS D. BLISS, OF NEW BEDFORD, MASSACHUSETTS, ASSIGNOR TO
HIMSELF AND DARIUS P. GARDNER, OF SAME PLACE.

IMPROVEMENT IN DIE-PLATES.

Specification forming part of Letters Patent No. 135,314, dated January 28, 1873.

To all whom it may concern:

Be it known that I, FRANCIS D. BLISS, of New Bedford, of the county of Bristol and State of Massachusetts, have made an invention of a new and useful Screw-Cutter or Apparatus for Cutting Male Screws of Various Diameters or Sizes; and I do hereby declare the same to be fully described in the following specification and represented in the accompanying drawing, of which—

Figure 1 is a top view. Fig. 2 is a sectional elevation of it, the plane of section being on the line *v w* of Fig. 1. Fig. 3 is a transverse section of it taken on line *x y* of Fig. 1.

My invention consists in the combination of two rotary die-plates of a novel character with independent carriers, as more fully hereinafter described, whereby the cutting-edges of the die-plates, when in use, may be always exposed to the view of the operator.

The two die-cutting plates may be made to occupy varied positions, and to present different cutting-edges for service, and the die-plates be capable of being readily removed and sharpened by the ordinary process of grinding.

In the drawing presented, A and B denote the two die-plates, which are mounted, respectively, on pivots or axes *a* within mortises in the carriers C and D, as shown. Each die-plate has several semicircular tapped recesses, adapted for cutting screws of different sizes; both plates exactly correspond in the number and size of recesses, and are so arranged, when in position, that the proper recesses may be brought coincident with each other. In each die-plate are several holes—one for each tapped recess—into which the stop-pins *d* are entered for the purpose of securing the die-plates in proper position, and preventing their movement independent of the carriers while in use. Each carrier is provided with or has a continuation, *e*, which is adapted for use as a handle, after the manner of those on ordinary die-plate holders. The carriers are connected by means of screw-bolts *f*, which are provided with circular tapped nuts *g*, which are confined longitudinally within circular recesses in the carriers by means of an annular groove in each nut and a key-pin, *h*. The nuts *g*, at their outer ends, may be made so as to be readily grasped with the hand, faced off

for a wrench, or provided with holes for receiving a wrench-pin. The plain end of each bolt *f* is secured in the opposite carrier by means of an enlarged head, which more than fills the aperture in said carrier, through which the threaded part of the bolt can freely pass. These apertures are somewhat elongated longitudinally at the inner sides of the carriers so as to admit of some slight change of position of the bolts with relation to the carriers.

It will be obviously essential that for cutting large and small screws the carriers and the die-plates must be separated by more or less space, and that the two adjusting-screws *f f* and their nuts *g g* are arranged to readily effect this necessary adjustment.

In order, when adjusted, that the carrier may be securely held I use the two stop-screws *i i*, each arranged as shown, and passed through a tapped hole in one of the carriers, and in contact, at its end, with the inner side of the opposite carrier. These screws may be provided with heads capable of being acted upon with a wrench or other similar device. In practice it will be preferable to have the heads of the stop-screws and the nuts *g* arranged to be readily worked by the same device.

The sides of the die-plates, between the tapped recesses, are cut at an angle of about forty-five degrees, so that each thread of the plate presents a cutting-face practically corresponding in its general character with the most approved face of a cutting or chasing tool adapted to screw work on a lathe.

As ordinarily made, die-plates, when dull or broken, must be first annealed before they can be filed up, after which they must necessarily be rehardened. This troublesome operation creates a tendency on the part of the workmen to so harden the plates that they will not readily become dulled; and in doing this they, in practice, too often overstep the mark, and make the plates so hard and brittle that they will break, crumble, and become utterly worthless. When constructed as described and shown, with the faces on the sides of the tapped recesses at the inclination substantially as stated, the die-plates may be readily ground on an ordinary grinding-wheel, and be kept in perfect order until finally so worn as to be absolutely worthless. As the cutting-

edges may thus be so readily kept in order it will not be essential to raise them to such a high degree of hardness as would render them liable to breakage.

In order to secure the desirable angle it will be preferable not to have more than, say, six different recesses in each plate, as shown.

By having the die-plates so mounted that the person using them may see between their faces while cutting a screw there need be little liability of a thread being torn, or a bad thread cut.

Whenever a long screw is to be cut, and it is deemed desirable to cut both ways, down and back, it can be readily accomplished, when the lower end of the thread is reached, by slightly slacking up one bolt *f*, and tightening on the other, so that the cutting-edges of the plates will be slightly advanced, and caused to sharply engage with the metal on the return movement. This method may also be adopted when, after having cut a perfect thread, it is found desirable to slightly reduce its diameter; or when the edges are slightly worn they may be made to engage more thoroughly with the metal by alternately slightly advancing opposite ends of the carriers.

For the use of plumbers and gas-fitters my improved screw-cutter is well adapted.

I am aware that it is not new to combine die-plates having several tapped recesses, intended for cutting screws of different sizes; but I know of none, prior to my invention, which were mounted in carriers capable of independent adjustment; or which were so faced as to present inclined cutting-edges, and be capable of being ground, and thereby kept in perfect condition.

Having thus described my invention, I claim as new, and desire to secure by Letters Patent—

1. The combination of the two die-plates with the two independent carriers, connected by the screw-bolts *f*, and arranged to be adjustable with relation to each other, substantially as and for the purposes specified.

2. The polygonal die-plates A and B, constructed substantially as described, with flat faces intervening between the tapped recesses, as and for the purposes specified.

FRANCIS D. BLISS.

Witnesses:

R. H. EDDY,
J. R. SNOW.